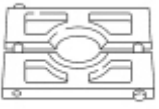
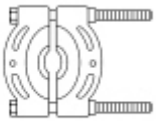

## Output Shaft

### Special Tool(s)

 <p>ST1310-A</p>	Remover, Bearing 205-055 (T71P-4621-B)
 <p>ST1895-A</p>	Remover, Drive Pinion Bearing Cone 205-D002 (D79L-4621-A) or equivalent

### Material

Item	Specification
MERCON® V Automatic Transmission Fluid XT-5-QM (or XT-5-QMC) (US); CXT-5- LM12 (Canada)	MERCON® V

### Transmission Internal Components — Output Shaft Disassembled View

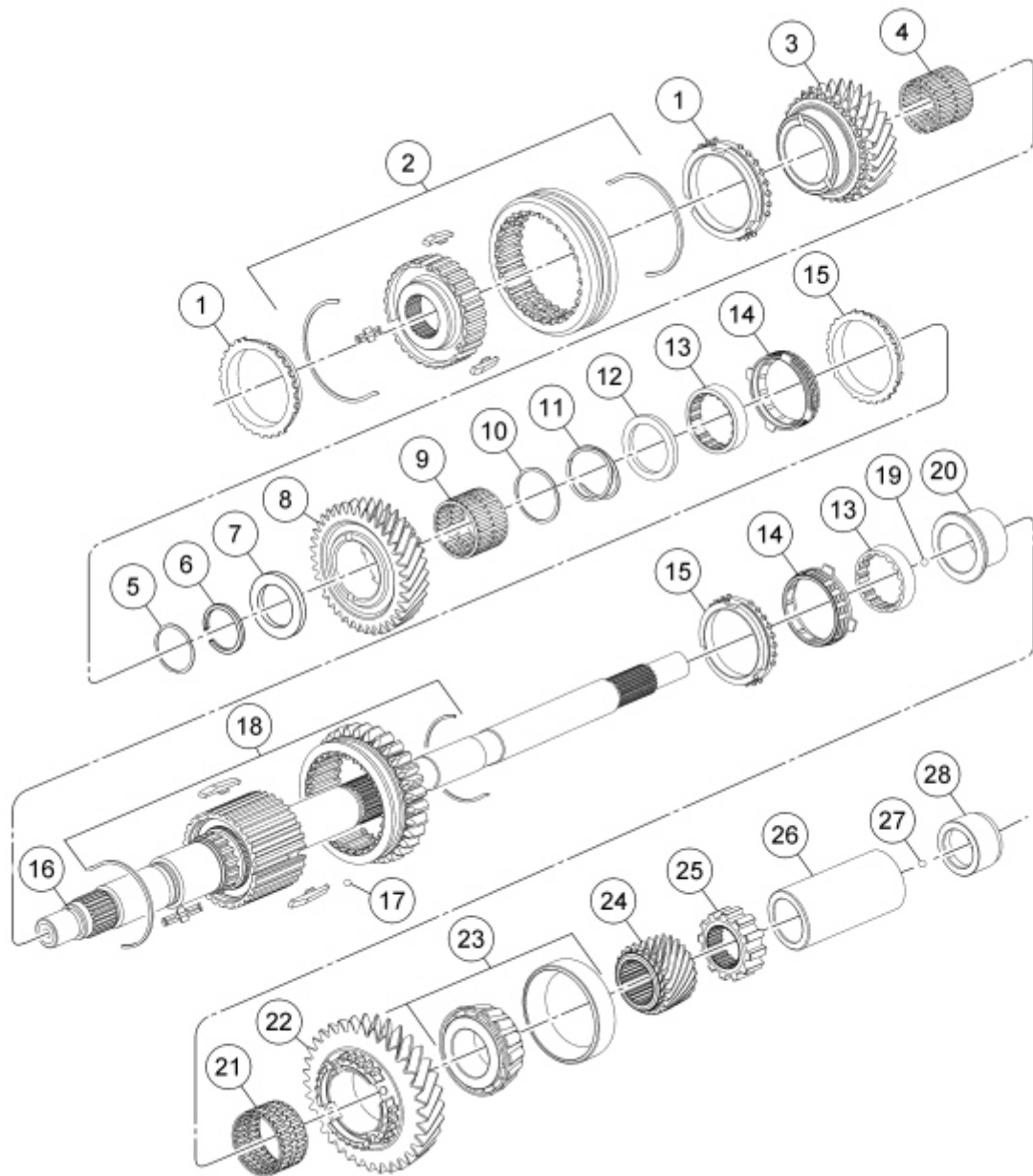

N0072634

Item	Part Number	Description
1	7107	3rd/4th gear synchronizer blocking rings
2	7124	3rd/4th gear synchronizer assembly
3	7B340	3rd gear
4	7B369	3rd gear needle bearing
5	7B320	3rd gear bearing spacer
6	7064	Snap ring
7	7119	Thrust washer
8	7102	2nd gear
9	7B369	2nd gear needle bearing
10	7B320	2nd gear bearing spacer
11	7160	Output shaft bearing snap ring
12	7117	2nd gear synchronizer thrust washer
13	7175	1st/2nd gear synchronizer inner cones

14	7107	1st/2nd gear synchronizer intermediate cones
15	7107	1st/2nd gear synchronizer blocking rings
16	7061	Output shaft and synchronizer assembly
17	7K218	1st/2nd gear synchronizer hub ball
18	7124	1st/2nd gear synchronizer assembly (serviced with 7061)
19	—	1st gear bearing spacer hub ball
20	7173	1st gear bearing spacer
21	7127	1st gear needle bearing
22	7100	1st gear
23	7065	Output shaft rear bearing and cup
24	7K316	Output shaft 5th gear
25	7H373	Output Shaft Speed (OSS) sensor ring
26	7A021	Output shaft inner spacer
27	—	Output shaft outer spacer hub ball
28	7065	Output shaft outer bearing and race assembly

## Disassembly

1. **NOTICE:** Support the output shaft while using the press to prevent damage to the shaft or gears.

Using the Bearing Remover, press the Output Shaft Speed (OSS) sensor ring from the output shaft.

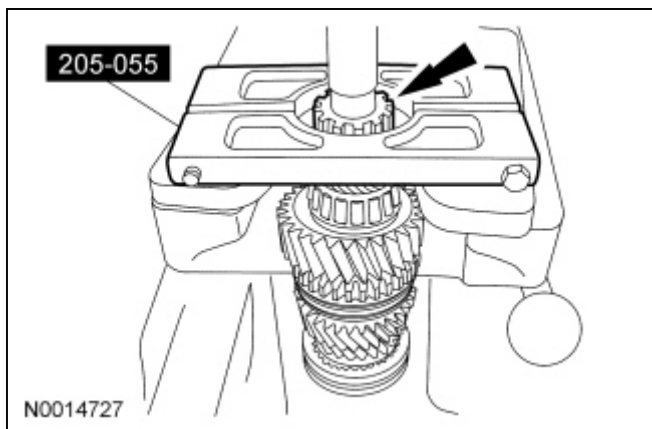

2. Using the Drive Pinion Bearing Cone Remover, press 1st gear, the output shaft rear bearing and the 5th speed driven gear from the output shaft as an assembly.
  - Discard the output shaft rear bearing.
  - Inspect the gears for wear or damage. Install new gears as necessary.

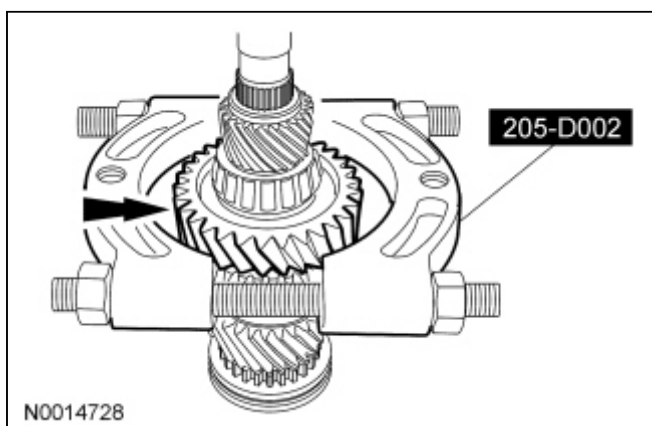

3. Remove 1st gear needle bearing.
  - Inspect the needle bearing for wear or damage. Install a new bearing as necessary.

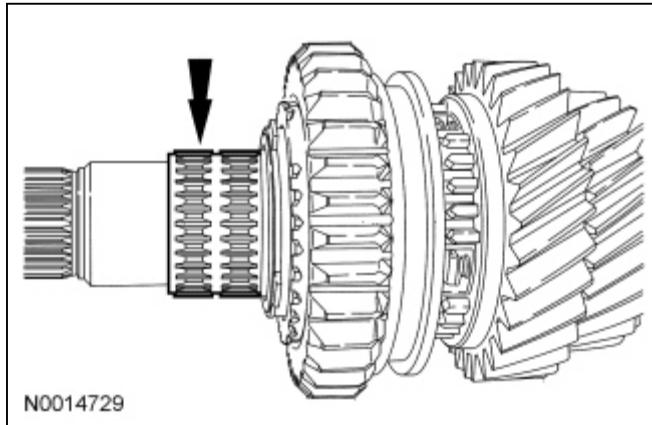

4. **NOTE:** The 1st gear bearing spacer fits snugly on the output shaft.

Remove the 1st gear bearing spacer.

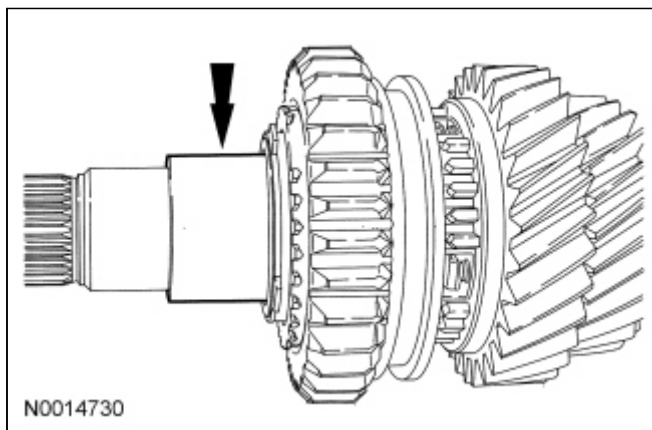

5. Remove the 1st and 2nd speed synchronizer hub ball.

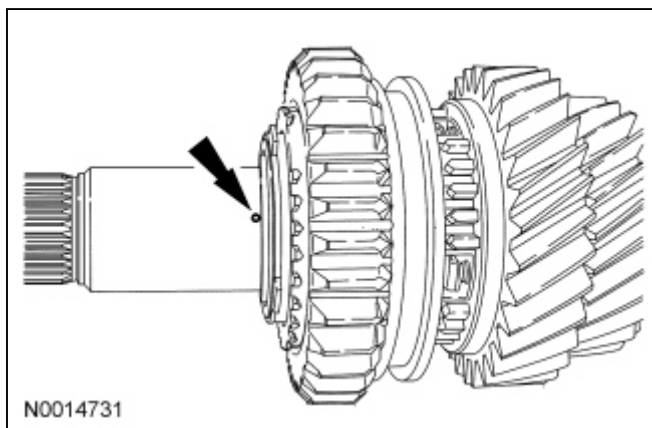

6. Remove the 1st gear synchronizer inner cone, 1st gear synchronizer outer cone and the 1st gear synchronizer blocking ring.

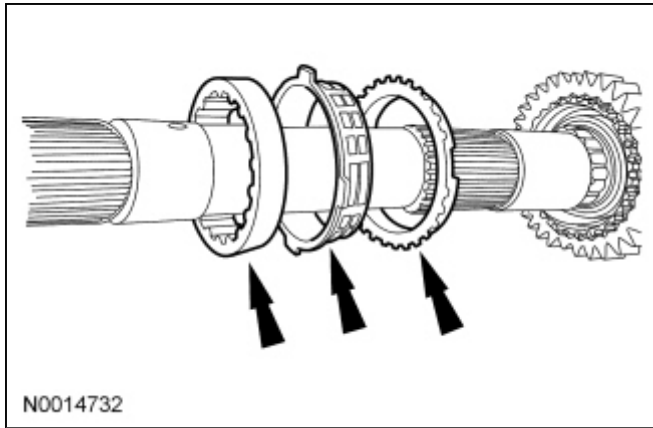

7. **NOTE:** Reposition the output shaft on the press with the input shaft end facing upward.

Using a suitable tool, remove the 3rd and 4th gear synchronizer assembly, the 3rd gear blocking ring and 3rd gear from the output shaft as an assembly.

- Inspect the gear for wear or damage. Install a new gear as necessary.

8. Disassemble and inspect the 3rd and 4th gear synchronizer assembly. For additional information, refer to [Synchronizers](#) in this section.
9. Remove 3rd gear needle bearing.
- Inspect the needle bearing for wear or damage. Install a new bearing as necessary.

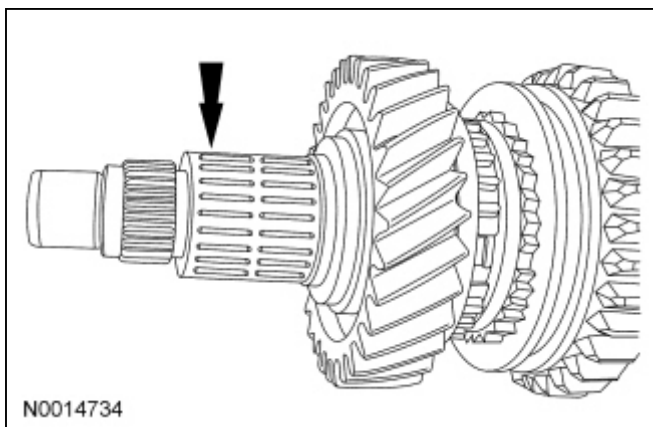

10. Remove the snap ring and discard.

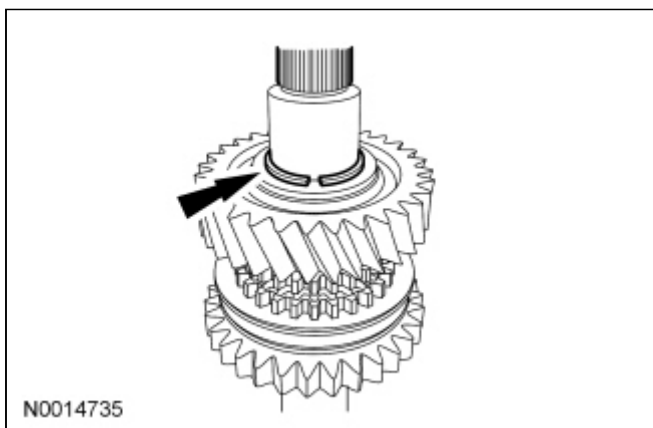

11. Remove the 2nd gear bearing spacer.

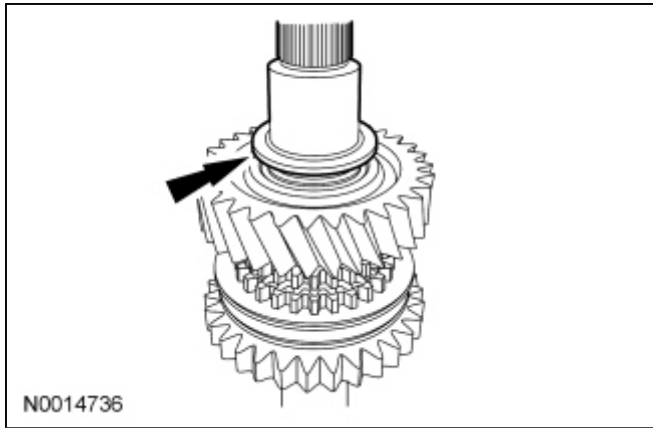

12. Remove 2nd gear.
  - Inspect the gear for wear or damage. Install a new gear as necessary.

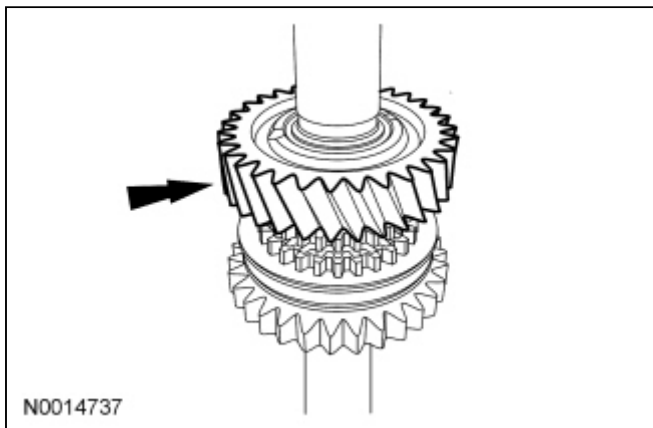

13. Remove 2nd gear needle bearing.
  - Inspect the needle bearing for wear or damage. Install a new bearing as necessary.

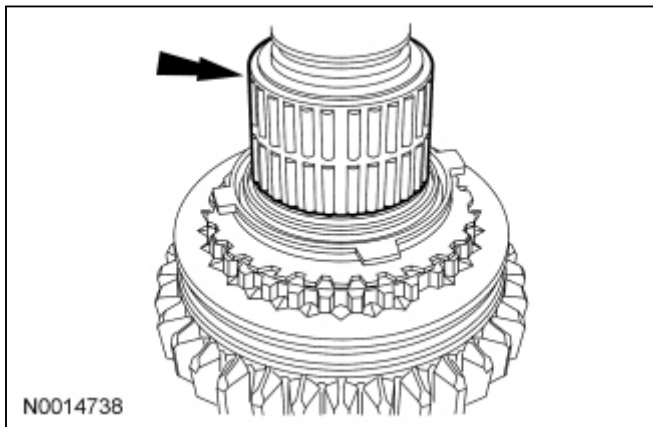

14. Remove the output shaft bearing snap ring and discard.

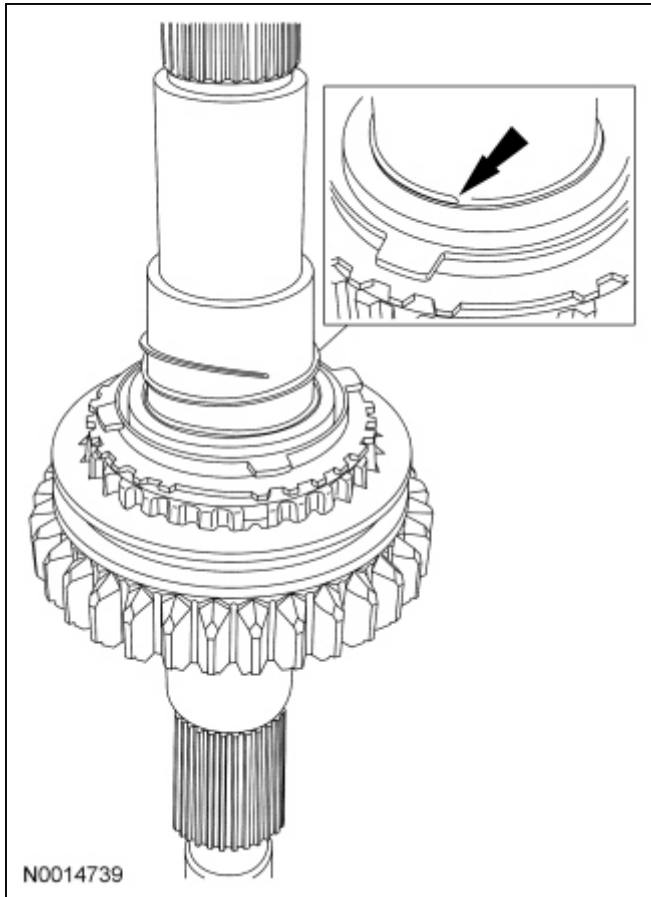

15. Remove the 2nd gear synchronizer thrust washer.

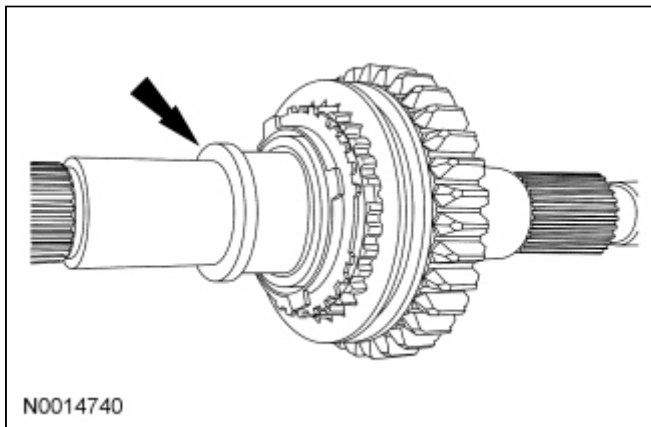

16. Remove the 2nd gear synchronizer inner cone, the 2nd gear synchronizer outer cone and the 2nd gear synchronizer blocking ring as an assembly.

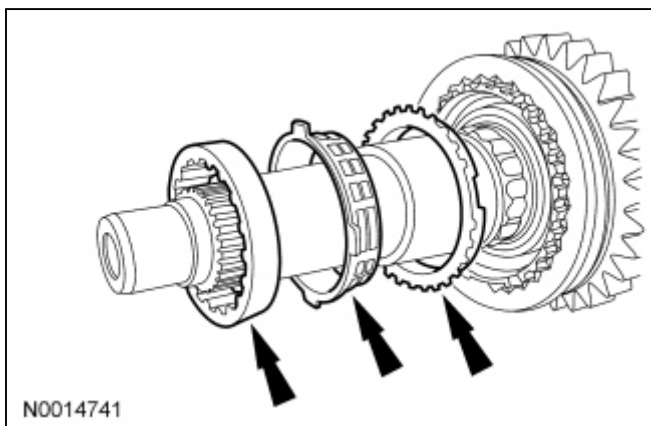

17. **NOTE:** The 1st and 2nd gear synchronizer sliding sleeve, the hub and the output shaft are an assembly. Do not attempt to separate the hub from the output shaft. Only the synchronizer hub insert springs and the synchronizer hub inserts are available separately.

Remove the 1st and 2nd gear synchronizer sliding sleeve. Disassemble and inspect the 1st and 2nd gear synchronizer assembly. For additional information, refer to [Synchronizers](#) in this section.

### Assembly

1. Lubricate all components with transmission fluid during assembly. Soak the blocking rings in transmission fluid.
2. Install the 1st and 2nd gear synchronizer hub insert springs and the synchronizer inserts into the synchronizer hub. Install the sliding sleeve onto the synchronizer hub.
3. **NOTE:** Align the slots in the synchronizer blocking ring with the tabs in the 1st and 2nd gear synchronizer.

Install the 2nd gear synchronizer blocking ring, the 2nd gear synchronizer outer cone and the 2nd gear synchronizer inner cone.

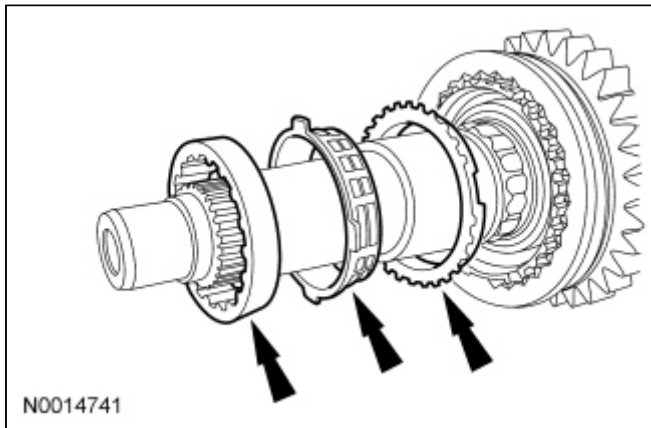

4. Install the 2nd gear synchronizer thrust washer.

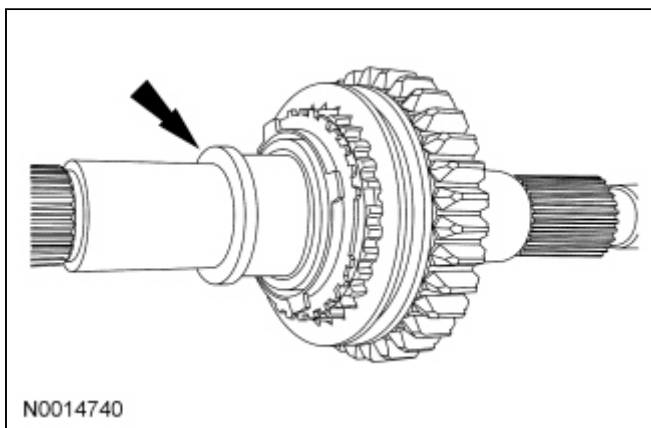

5. Install the new output shaft bearing snap ring.



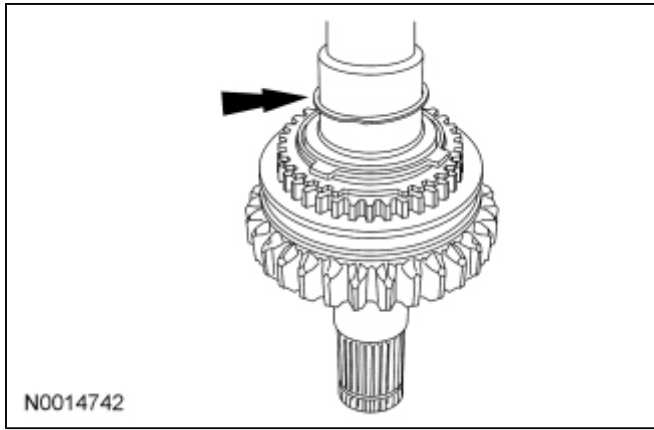

6. Install the 2nd gear needle bearing.

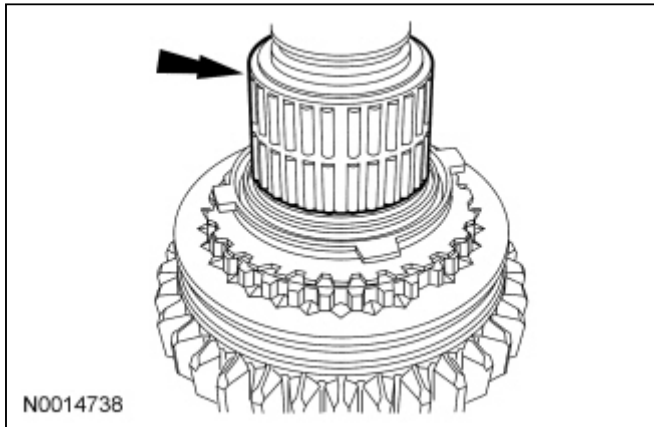

7. Align the slots on 2nd gear with the tabs on the synchronizer blocking ring. Install 2nd gear.

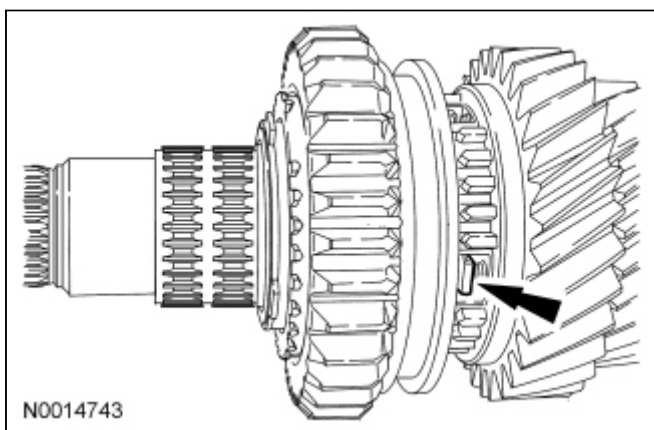
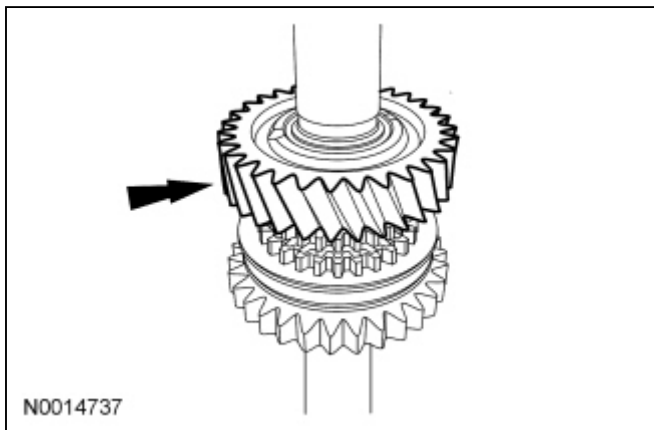

8. Install the 2nd gear bearing spacer.

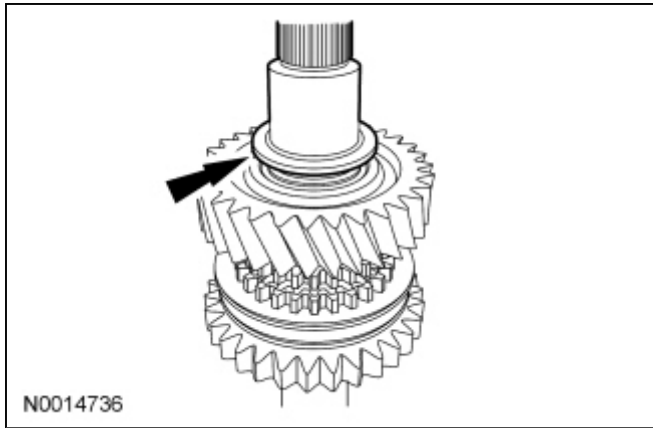

9. Install a new snap ring.

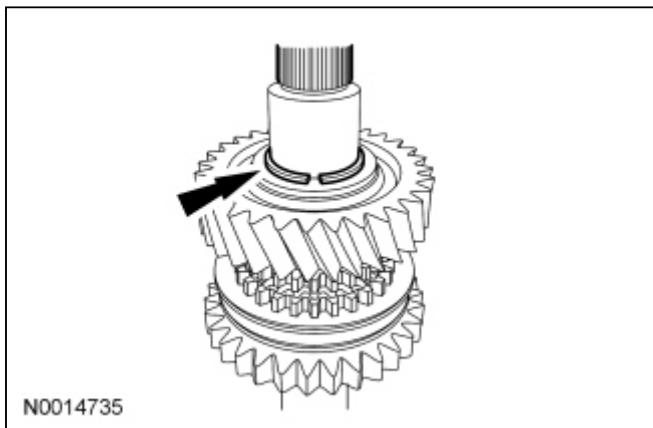

10. Install 3rd gear needle bearing.

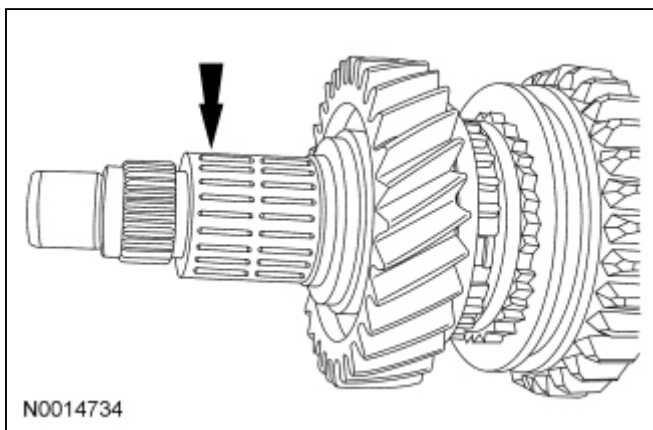

11. **NOTE:** Align the slots on 3rd gear with the tabs on the synchronizer blocking ring.

Position 3rd gear, the 3rd gear synchronizer blocking ring and the 3rd and 4th gear synchronizer assembly onto the output shaft.

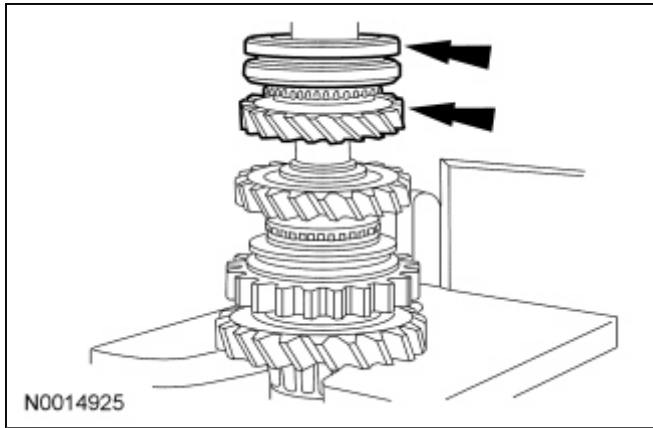

12. **NOTE:** Before pressing the components together, verify that the synchronizer hub faces the short end of the output shaft. Hold 3rd gear against the synchronizer to maintain the synchronizer blocking ring alignment.

Using a 1-1/2-inch deep-well socket, press the 3rd gear, the 3rd gear synchronizer blocking ring and the 3rd and 4th gear synchronizer assembly onto the output shaft.

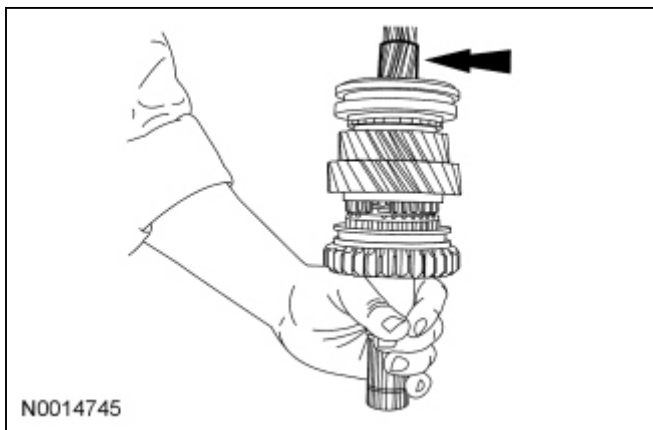

13. **NOTE:** Reposition the output shaft on the press with the output end facing upward.

Install the 1st gear synchronizer blocking ring, the 1st gear synchronizer outer cone and the 1st gear synchronizer inner cone.

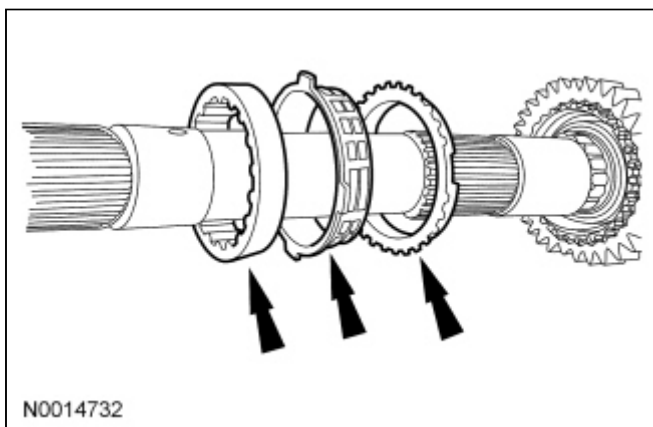

14. Install the 1st and 2nd gear synchronizer hub ball.

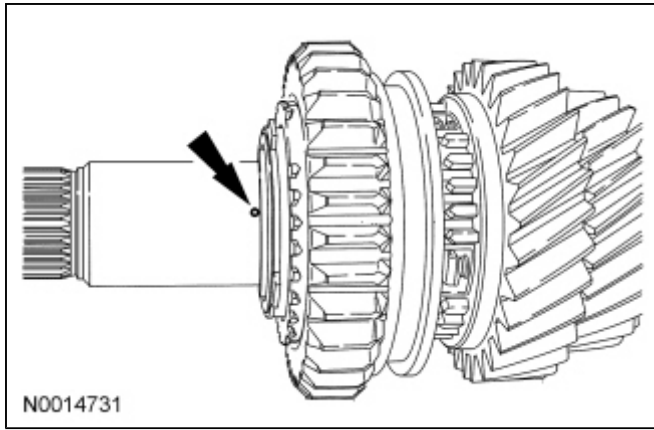

15. **NOTE:** The 1st gear bearing spacer fits snugly on the output shaft.

Align the notch in the 1st gear bearing spacer and the 1st and 2nd gear synchronizer hub ball. Install the 1st gear bearing spacer.

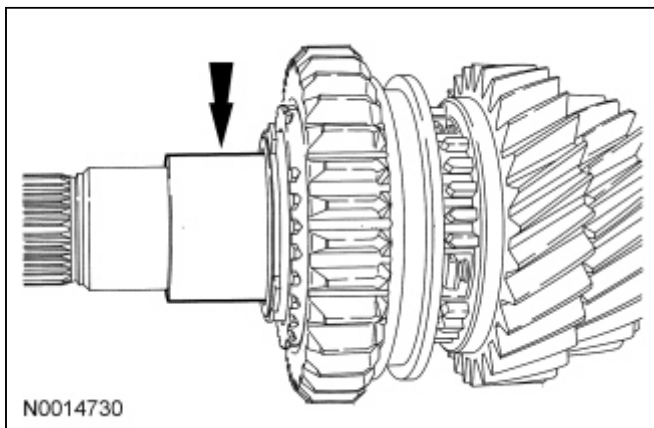
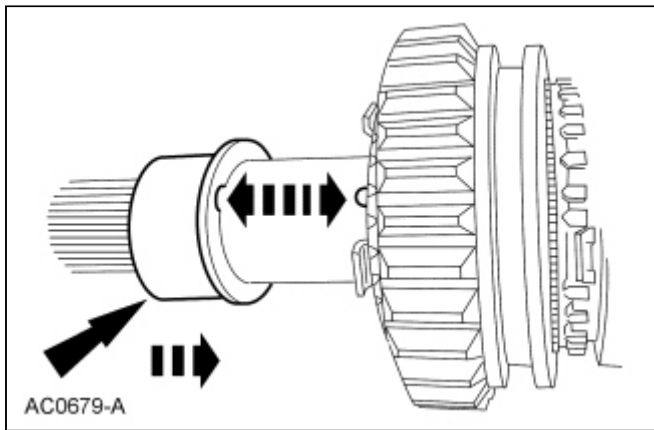

16. Install the 1st gear needle bearing.

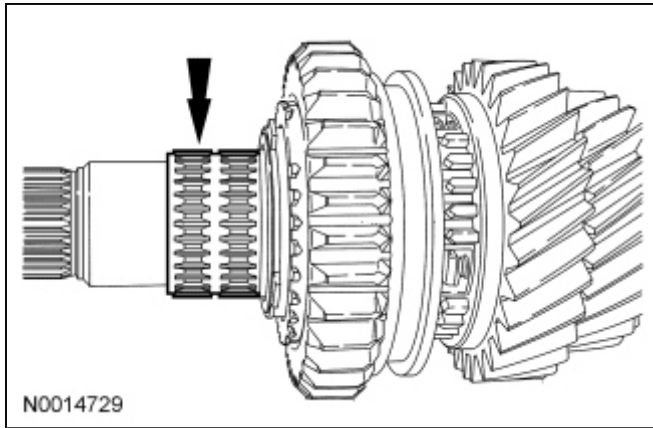

17. Align the slots on the synchronizer blocking ring and the slots on the 1st gear. Install 1st gear.

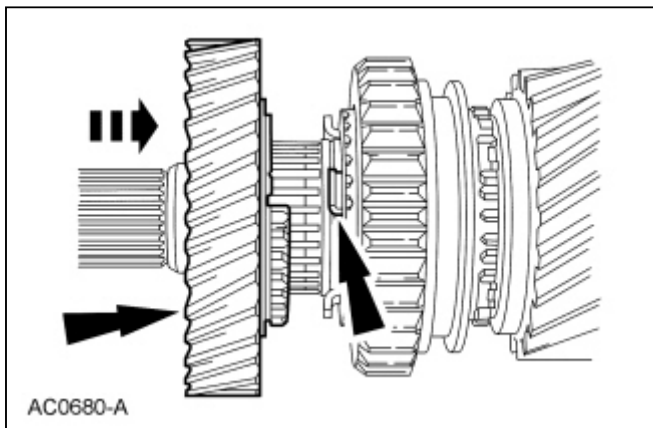

18. Install the output shaft rear bearing.

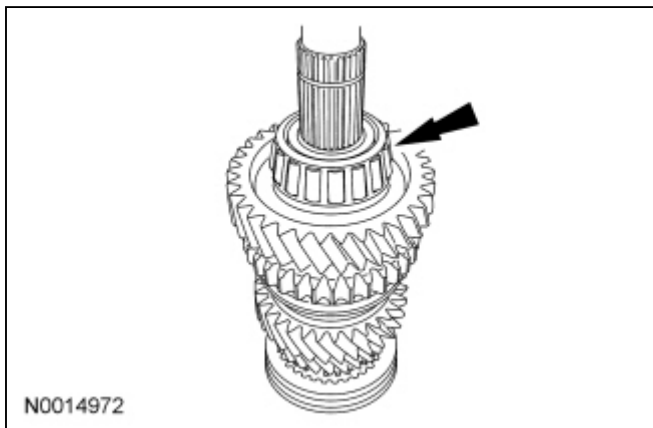

19. **NOTICE:** Align the output shaft splines and the splines of the 5th speed driven gear or damage will occur.

Lubricate the splines of the 5th speed driven gear with petroleum jelly. Position the 5th speed driven gear on the output shaft. Using a capped length of pipe 31.7 mm (1.248 in) inside diameter by 356 mm (14.015 in) long, press on the 5th speed driven gear.

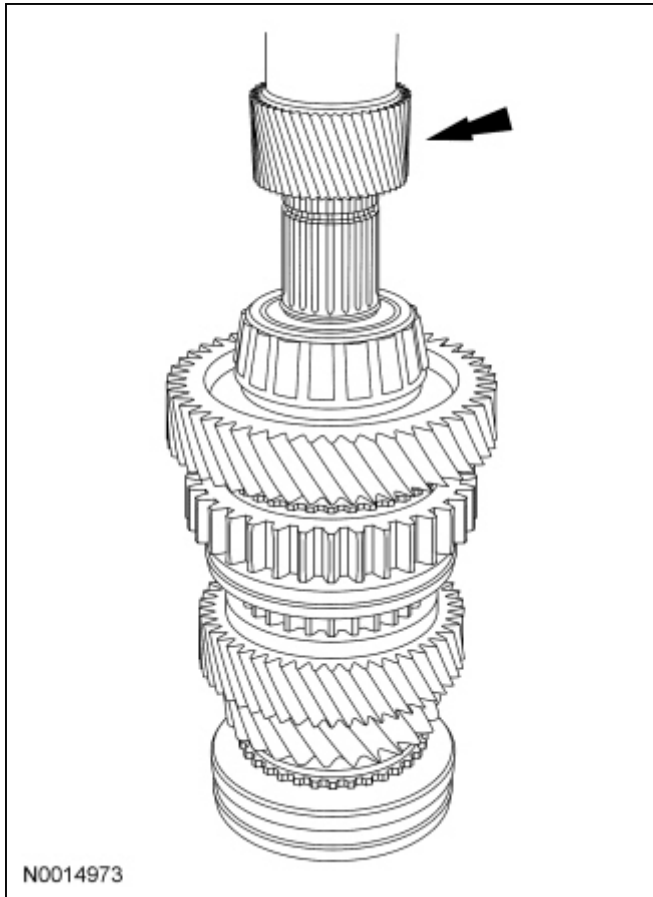

20. Using the capped length of pipe 31.7 mm (1.248 in) inside diameter by 356 mm (14.015 in) long, press the OSS sensor ring on the output shaft.

